

RANGER RESIDENTIAL IRON FENCE PANEL

HEIGHT : 48"
 WIDTH : 94"
 WEIGHT : 41.19 LBS
 FINISH : POWDER COATED BLACK
 ITEM# : KIRAN48R8
 DETAILS : 1/2" X 1/2" SQ PICKETS, 1" X 1" SQ RAIL, 3 7/8" SPACING BETWEEN PICKETS

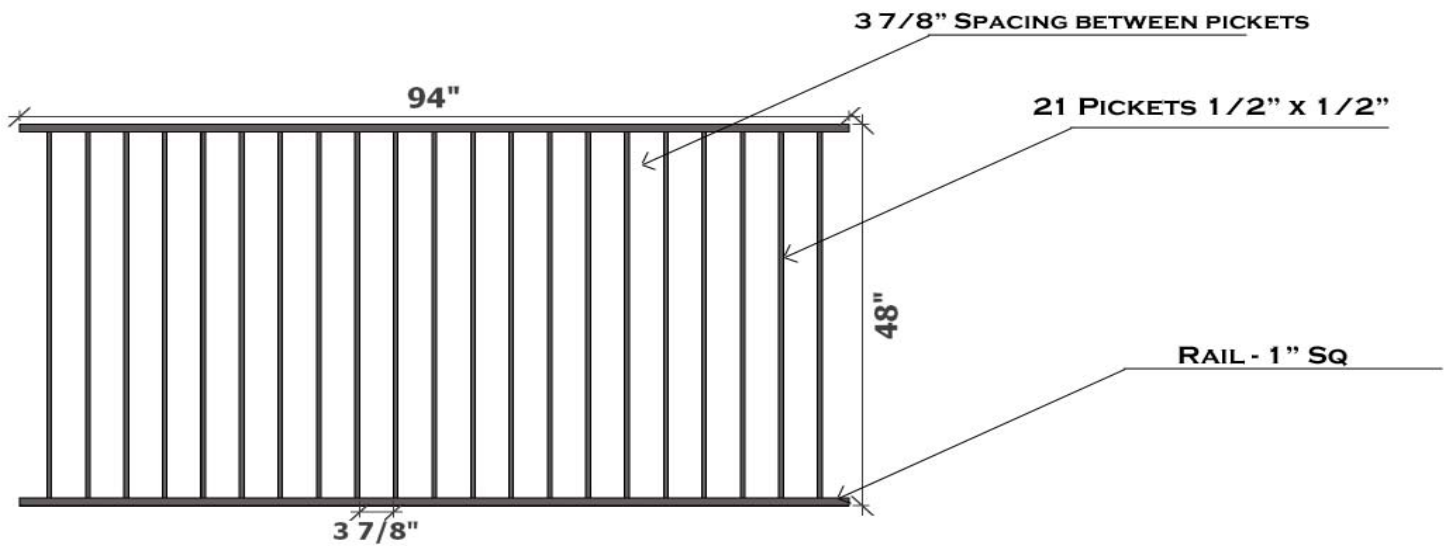

Proudly Distributed By:

Drawn By: Sharp, W	Description:		
Checked By: Wingo, C	Ranger Residential Iron Fence Panel		
Date: September 23, 2011			
Customer: Kodiak Iron	DWG. No: 1 of 1	SERIES: Ranger	
	APPLICATION: Residential		